

# KORTE® Concave Mouldings

- Industrially prefabricated profiles – ready for use
- For new buildings and refurbishments, for use indoors and outdoors
- Waterproof, frost resistant and weather-proof
- The ideal solution for all floor/wall junctions

## ■ KORTE® Concave Moulding

Types H30/30  
H50/25  
H50/50  
H70/50  
H100/50  
H150/40

→ 'Bottle-shaped' concave moulding for all standard applications

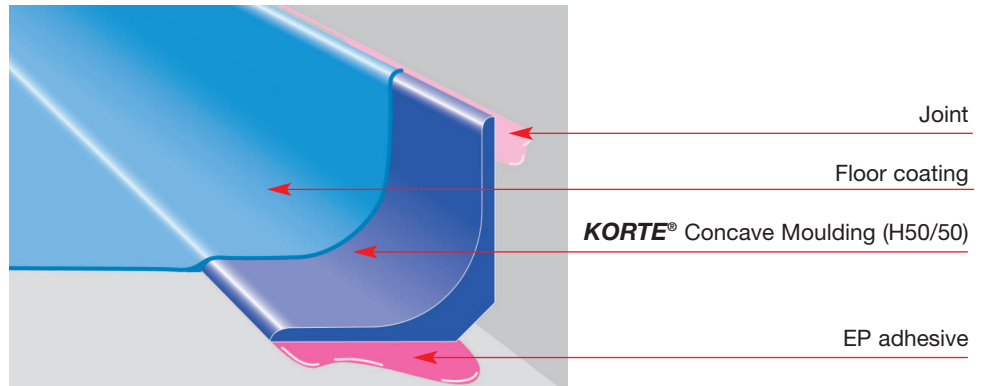

## ■ KORTE® Concave Moulding

Types H30/30  
H50/25  
H50/50  
H70/50  
H100/50  
H150/40

→ 'Bottle-shaped' concave moulding with joint formation compliant with DIN 18 540

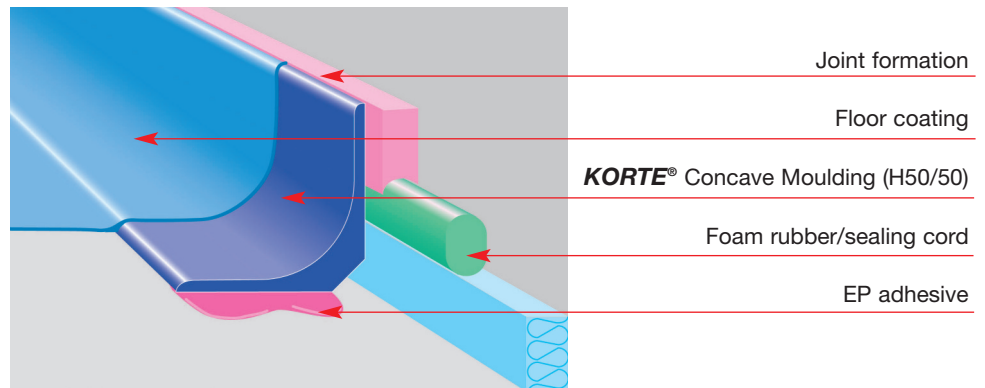

## ■ KORTE® Concave Moulding

Types H30/30  
H50/25  
H50/50  
H70/50  
H100/50  
H150/40

→ Example: With thermal insulation composite system

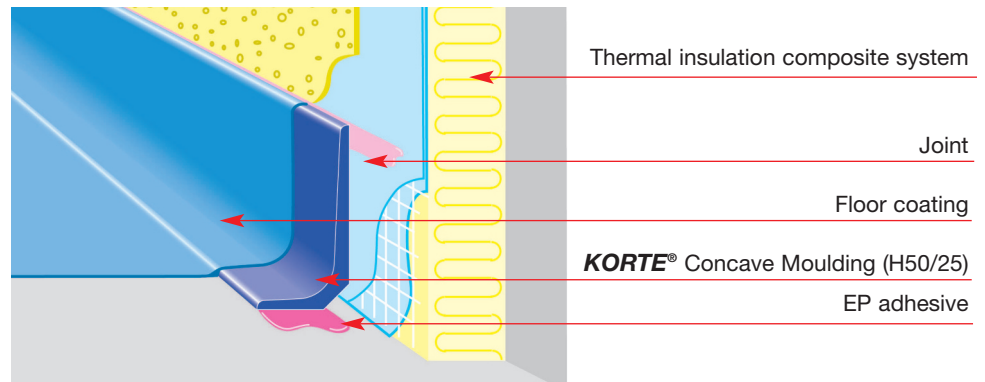

## ■ KORTE® Concave Moulding

Types H30/30  
H50/25  
H50/50  
H70/50  
H100/50  
H150/40

→ Examples:  
① tiled wall  
② drywall with set-screws

